

# Þreytuáraun á stálbrýr á Íslandi

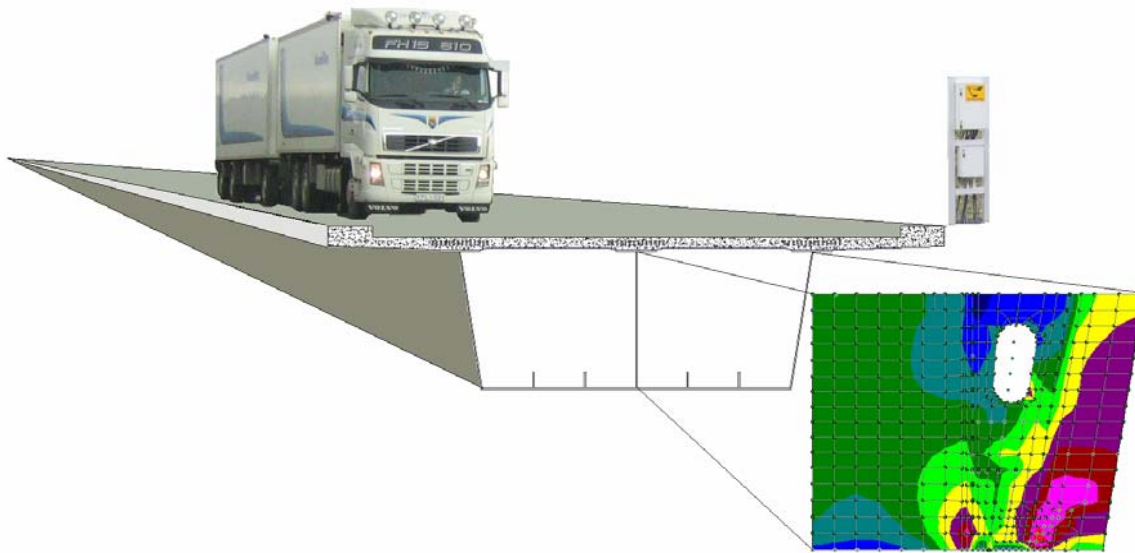

**Jóhannes Loftsson**

**Meistaraverkefni á Umhverfis- og  
byggingarverkfræðiskor Háskóla Íslands**

# Inngangur

- Brúarhönnun, álagslíkan, hönnun samverkandi sniðs og þverplötu.
- Þreytuhönnun með þreytuálagslíkönunum sem eru byggð á reynslutölum.
- Þreytuhönnun byggð á raunmælingum: 6 mánaða mæligögn úr umferðargreinum Vegagerðarinnar.

# Sundabraut



Mynd 2.27 Eyjafur og 100 ill.  
Útmynd.

# Sundabraut



Mynd 2.27 Eyjafjall og 100 ill.  
Útgrýnd.

# Samverkandi Stál/steypu kassabitaþrú

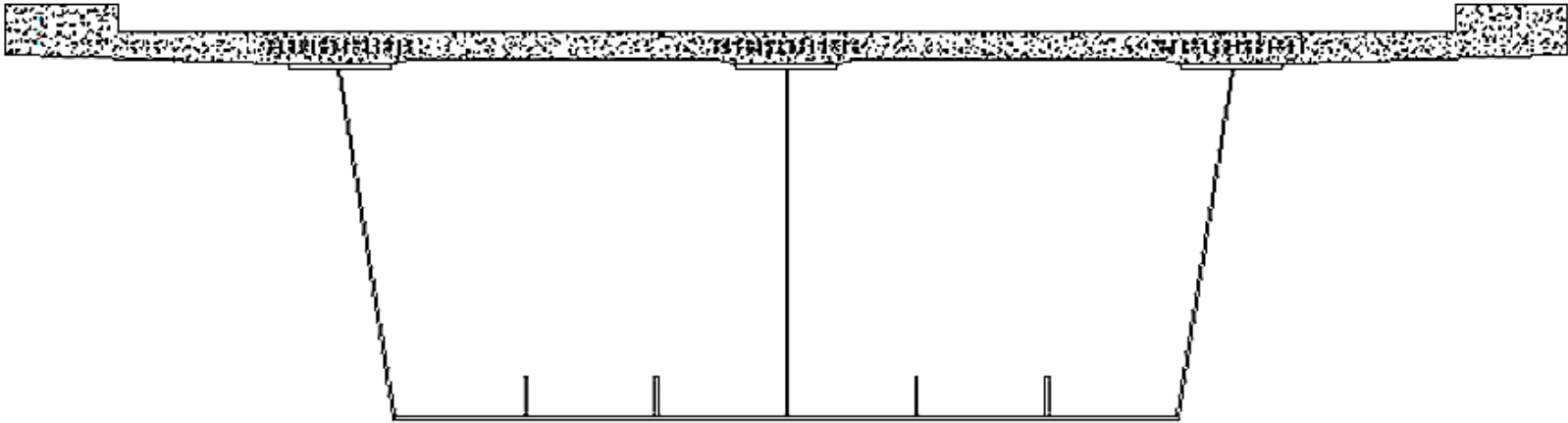

# Samverkandi Stál/steypu kassabitaþrú



# Málmþreyta

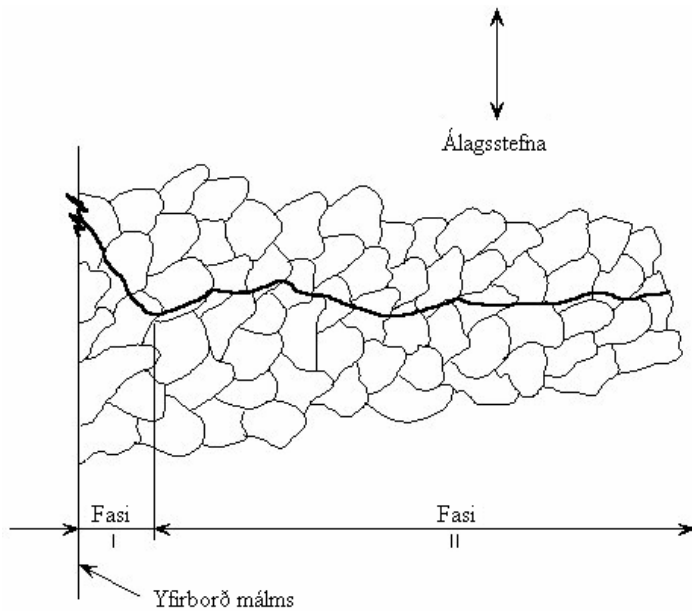

- Síendurtekið álag
- Brot við litla áraun

# Sprunguvöxtur

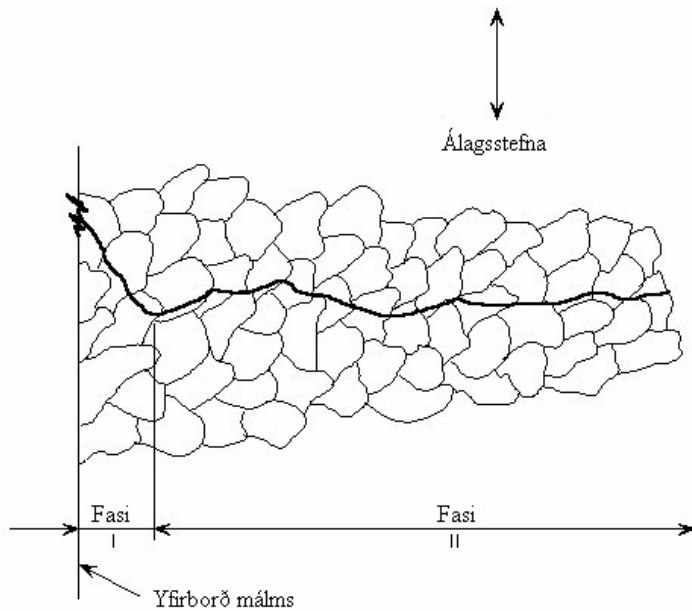

- Fasi I: Sprungumyndun
- Fasi II: Vöxtur meginsprungu
- Fasi III: Brot
- Óháð efnisstyrk stáls
- Tengir viðkæmust (suður)
- Gæðakröfur til hönnunar, verklags, eftirlits



# Þreytugreining deila

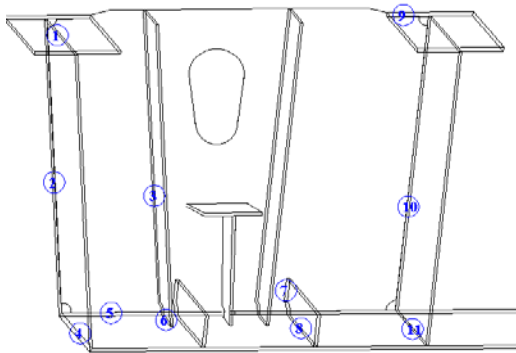

- Allar suður greindar
  - Þreytuflokka
  - Öryggisstuðlar

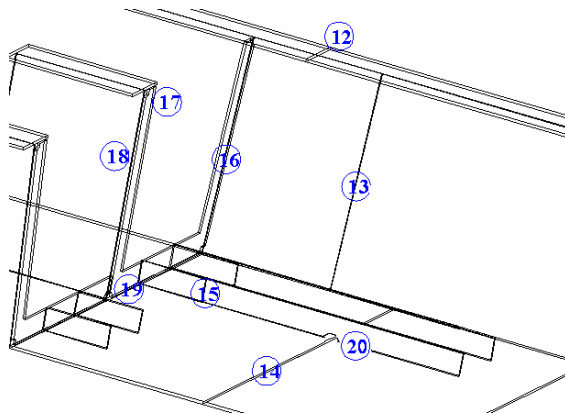

- Eitt deili skoðað nánar

# Þreytuhönnun (Reynslutölur yfir umferðarálag)

- Þreytuálagslíkön fyrir þreytustyrk
  - Deilið þarf að lágmarki að vera í þreytuflokki 56 (frekar veikt)
- Þreytuálagslíkön fyrir þreytuendingu
  - Deili í lélegasta þreytuflokki endist aðeins 22 ár

# Þreytuhönnun (Mælt umferðarálag)

## Umferðarmælingar:



- Þyngdargreinir
  - Öxulþyngd, Öxulbil, Bílaflokkur, Hraði, Tími o.fl.
- Ástandsmælingar
  - Mælingar í upphafi og lok sumars

# Þreytuhönnun (Mælt umferðarálag)

## Umferðarmælingar:



- Þyngdargreinir
  - Öxulþyngd, Öxulbil, Bílaflokkur, Hraði, Tími o.fl.
- Ástandsmælingar
  - Mælingar í upphafi og lok sumars
  - Leiðréttingarstuðull:  
 $0.507 \pm 0.026$























# Þreytuhönnun (Mælt umferðarálag)

## Einföldun gagna:

- Ónýtar mælingar tíndar út
- Einföldun gagna m.t.t. þreytuhegðunar
  - 10 tonna bílar aðskildir

# Þreytuhönnun (Mælt umferðarálag)

## Sundurgreining ökutækja:

Vehicle Classification Table			GR03-EUR13			
1	Car, Light Van		6	Rigid 3-Axle HGV & 2-Axle Drawbar Trailer		
	Light Goods Vehicle (LGV)			Rigid 3-Axle HGV & 3-Axle Drawbar Trailer		
	Car/LGV & 1-Axle Caravan/Trailer		7	Artic, 2-Axle Tractor & 1-Axle Semi-Trailer		
	Car/LGV & 2-Axle Caravan/Trailer			8	Artic, 2-Axle Tractor & 2-Axle Semi-Trailer	
2	Rigid 2-Axle Truck (HGV)		9	Artic, 2-Axle Tractor & 3-Axle Semi-Trailer		
	3	Rigid 3-Axle Truck (HGV)			10	Artic, 3-Axle Tractor & 1-Axle Semi-Trailer
	Rigid 3-Axle Truck (HGV)			Artic, 3-Axle Tractor & 2-Axle Semi-Trailer		
4	Rigid 4-Axle Truck (HGV)		11	Artic, 3-Axle Tractor & 3-Axle Semi-Trailer		
		Rigid 4-Axle Truck (HGV)			12	Bus or Coach 2-Axle
5	Rigid 2-Axle Truck & 2-Axle Drawbar Trailer			Bus or Coach 3-Axle		
		Rigid 2-Axle Truck & 3-Axle Drawbar Trailer		13	Vehicle with 7 or more Axles	
		Rigid 2-Axle Truck & 1-Axle Caravan/Trailer				Vehicle not classified above
	Rigid 2-Axle Truck & 2-Axle Trailer/Caravan					

– Ökutækjaflokkun skv. GR03-EUR13.

# Þreytuhönnun (Mælt umferðarálag)

Leiðrétting gagna fyrir líkan :

- Umferðarmælingar gefa víxlverkunina.

- .

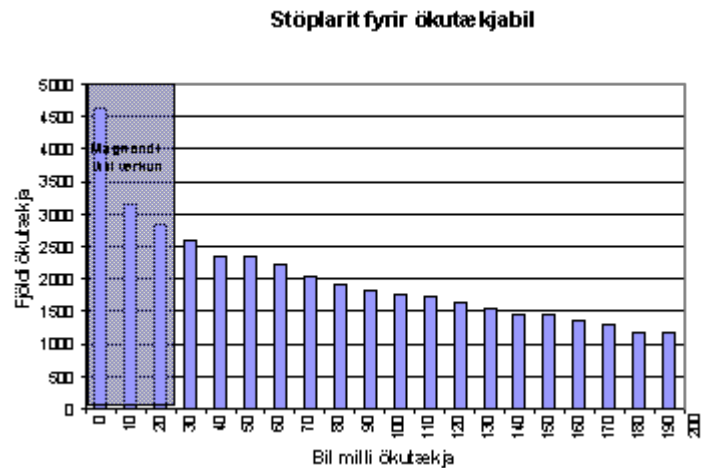

# Þreytuhönnun (Mælt umferðarálag)

Leiðrétting gagna fyrir líkan :

- Umferðarmælingar gefa víxlverkunina.
- Millibæjarumferð vs. innanbæjarumferð





# Þreytuhönnun (Mælt umferðarálag)

## Umferðarspá - Þreytuending:

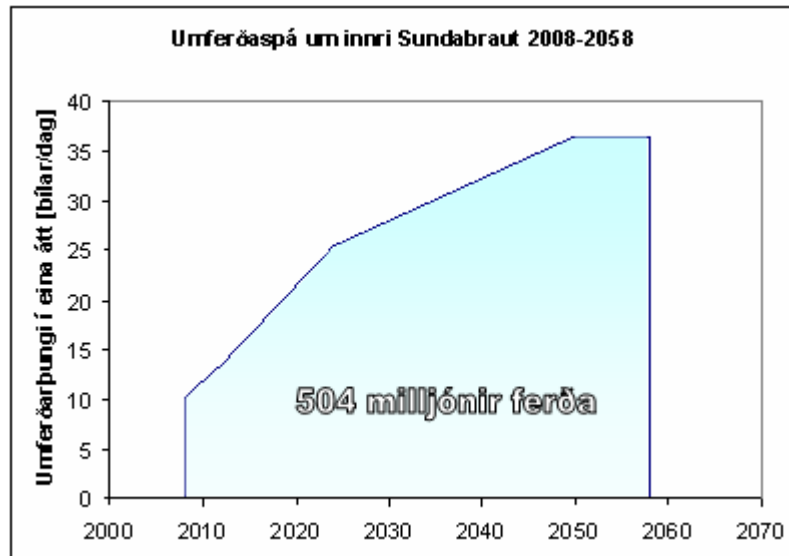

- Deili í þreytuflokki 36 → 23 ár
- Deili í þreytuflokki 71 → 810 ár
- Tveir ökutækjaflokkar valda meginþorra skemmda.

# Samantekt

- Álagslíkönum ber vel saman.
- Huga þarf að þreytuáraun við hönnun stórra umferðarmannvirkja á höfuðborgarsvæðinu.
- Með réttri hönnun tengja má komast hjá þreytuvandamálum.
- Þyngdargreinir Vegagerðarinnar
  - Forsenda rannsóknarvinnunnar
  - Sundurgreiningu ökutækjaflokka reyndist vel

# Þreytuáraun á stálbrýr á Íslandi

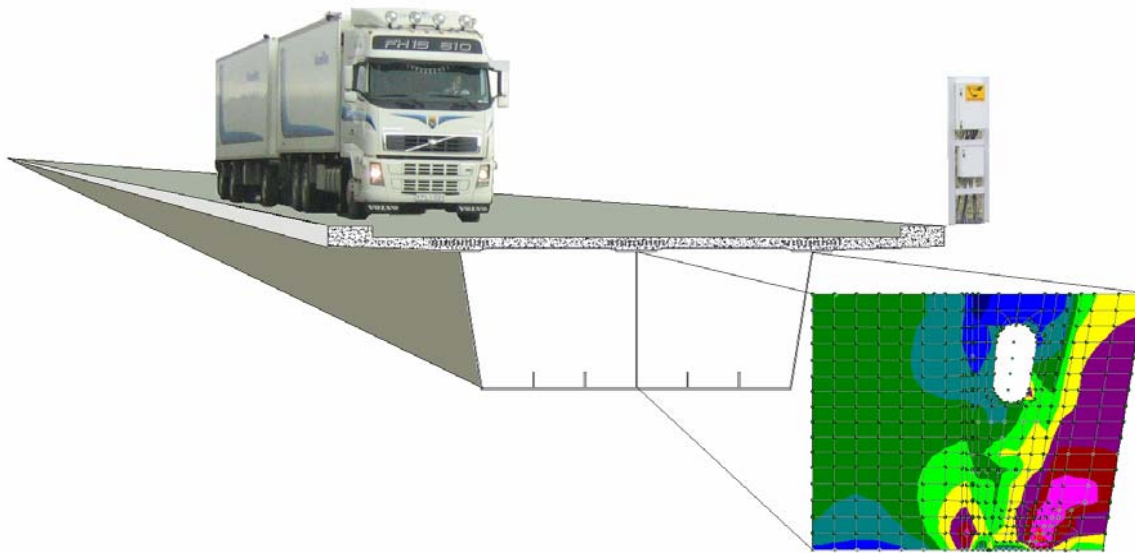

**Jóhannes Loftsson**

**Meistaraverkefni á Umhverfis- og  
byggingarverkfræðiskor Háskóla Íslands**